

CLASS[®]

DS96GM5-SOA

Drive Axle Rear Suspensions
for 2013+ Chevrolet/GMC G4500
Based Low Floor Bus with Rear
Mounted Fuel Tanks

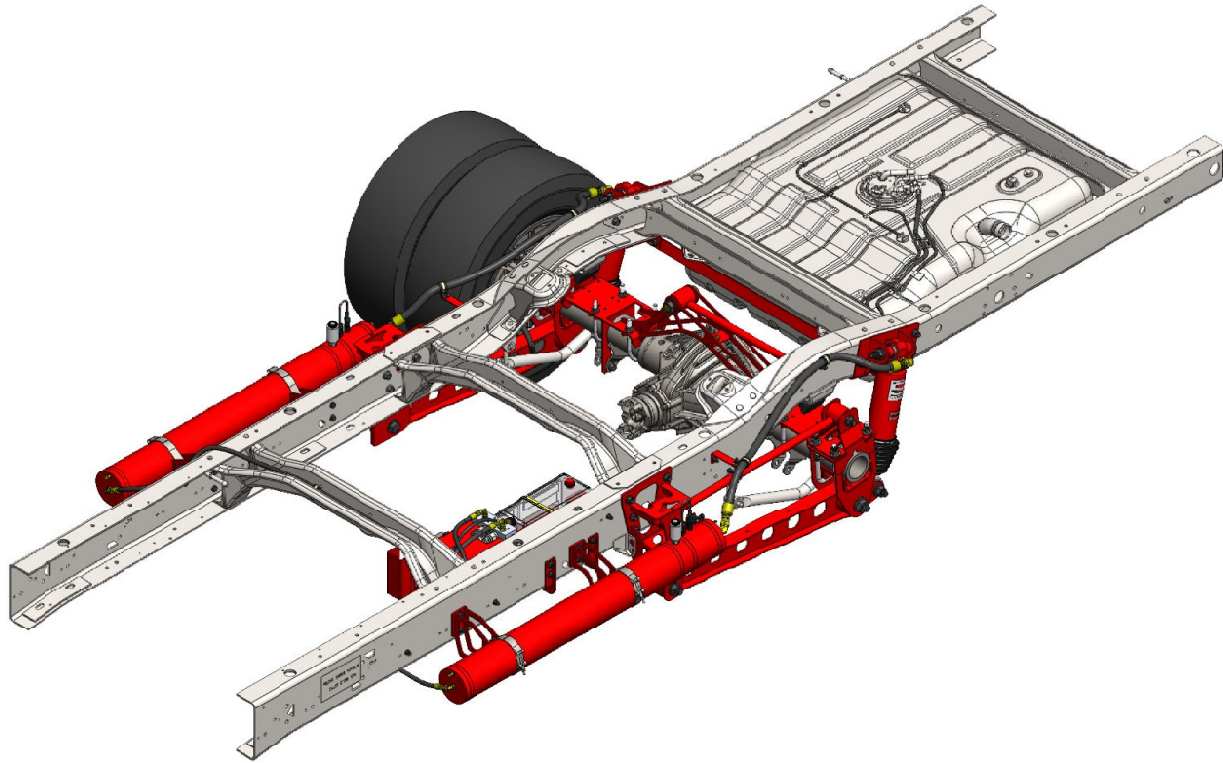

- Non-torque reactive design optimized with CLASS[®]
- Maintains proper driveline geometry through full range of torque inputs reducing driveline noise, vibration, and fatigue
- Variable stiffness and damping adjusted automatically and instantaneously based on road conditions without driver intervention
- Utilizes high performance leveling system designed for bus applications
- Does not require modification to exhaust
- Compact package space claim
- 9,600 lbs GAWR



SMART SUSPENSION

DS96GM5-SOA Drive Axle Rear Suspension for Chevrolet/GMC G4500 Based Low Floor Bus with Rear Mounted Fuel Tanks

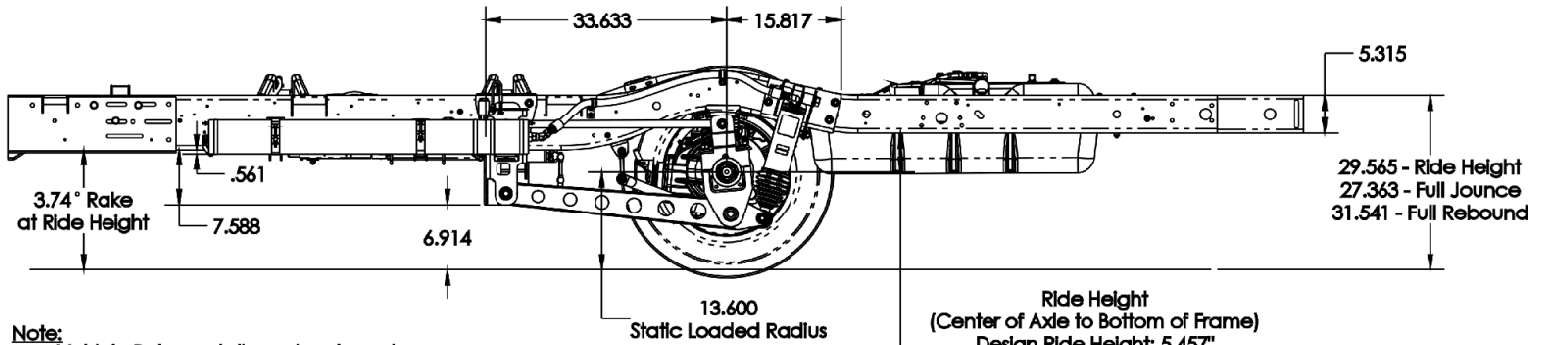
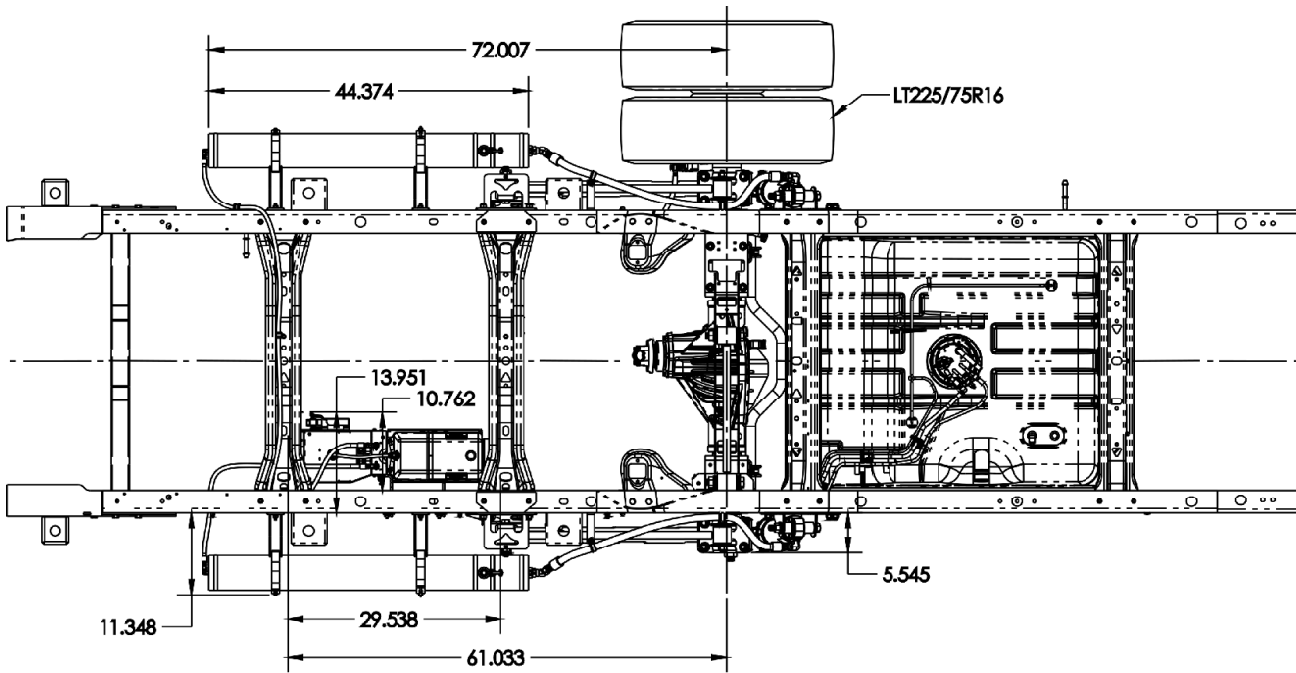

- Note:**
- Vehicle Rake and dimensions based on:
 - OEM tires & LiquidSpring front suspension
 - 191" Wheelbase
 - Add or subtract Static Loaded Radius difference for different tires

Ride Height
(Center of Axle to Bottom of Frame)
 Design Ride Height: 5.457"
 Full Jounce Height: 2.457"
 Full Rebound Height: 7.979"
 3.00" Jounce Travel
 2.52" Rebound Travel



LiquidSpring™ LLC

4899 E 400 S
Lafayette, IN 47905

Phone: 765-474-7816

Fax: 765-474-7826

Web: www.liquidspring.com