

[®]
CLASS

FS46GM-SOA

Front Axle Suspension
for 2013+ Chevrolet/GMC G4500
Based Low Floor Bus with Rear
Mounted Fuel Tanks

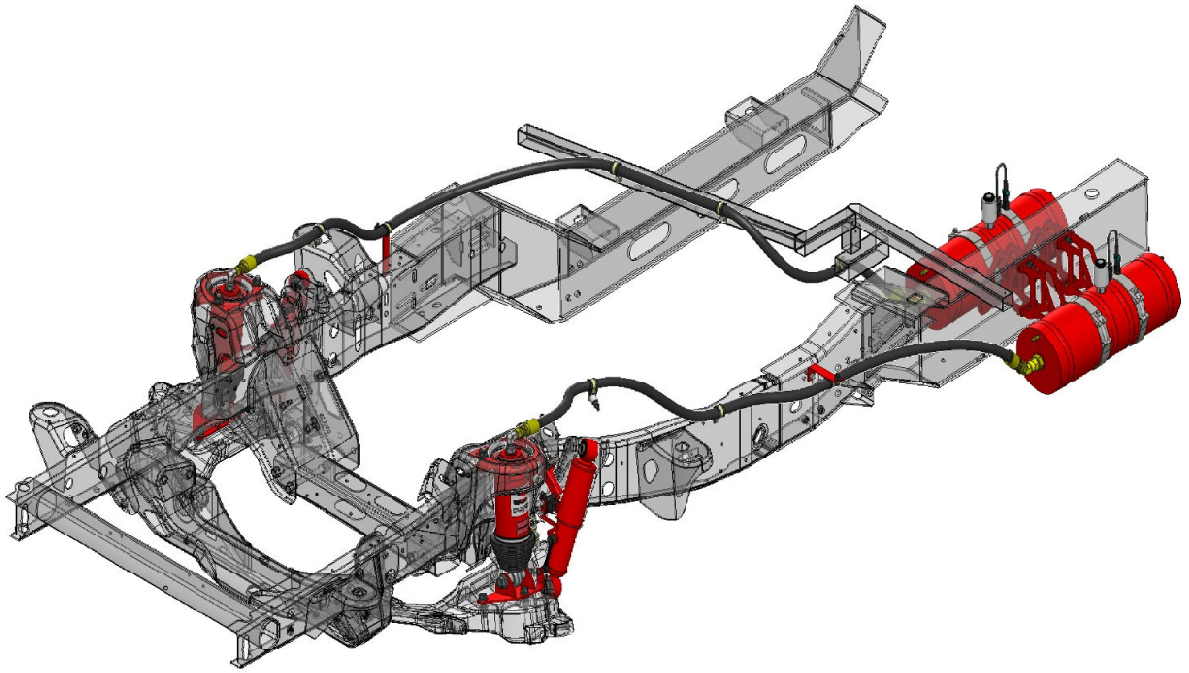

- Non-torque reactive design optimized with CLASS[®]
- Maintains proper driveline geometry through full range of torque inputs reducing driveline noise, vibration, and fatigue
- Variable stiffness and damping adjusted automatically and instantaneously based on road conditions without driver intervention
- Utilizes high performance leveling system designed for bus applications
- Compact package space claim
- 4,600 lbs. GAWR



SMART SUSPENSION

FS46GM-SOA Front Axle Suspension for Chevrolet/GMC G4500 Based Low Floor Bus with Rear Mounted Fuel Tanks

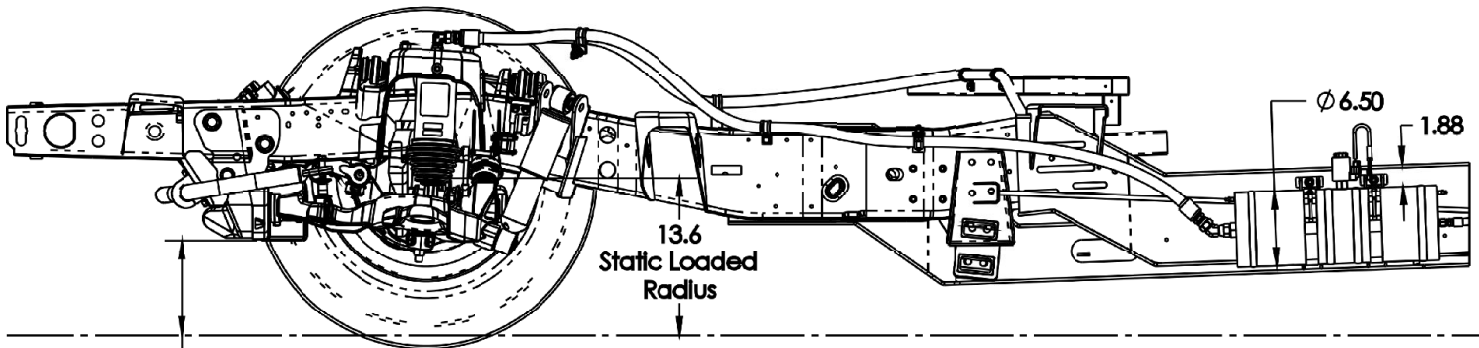
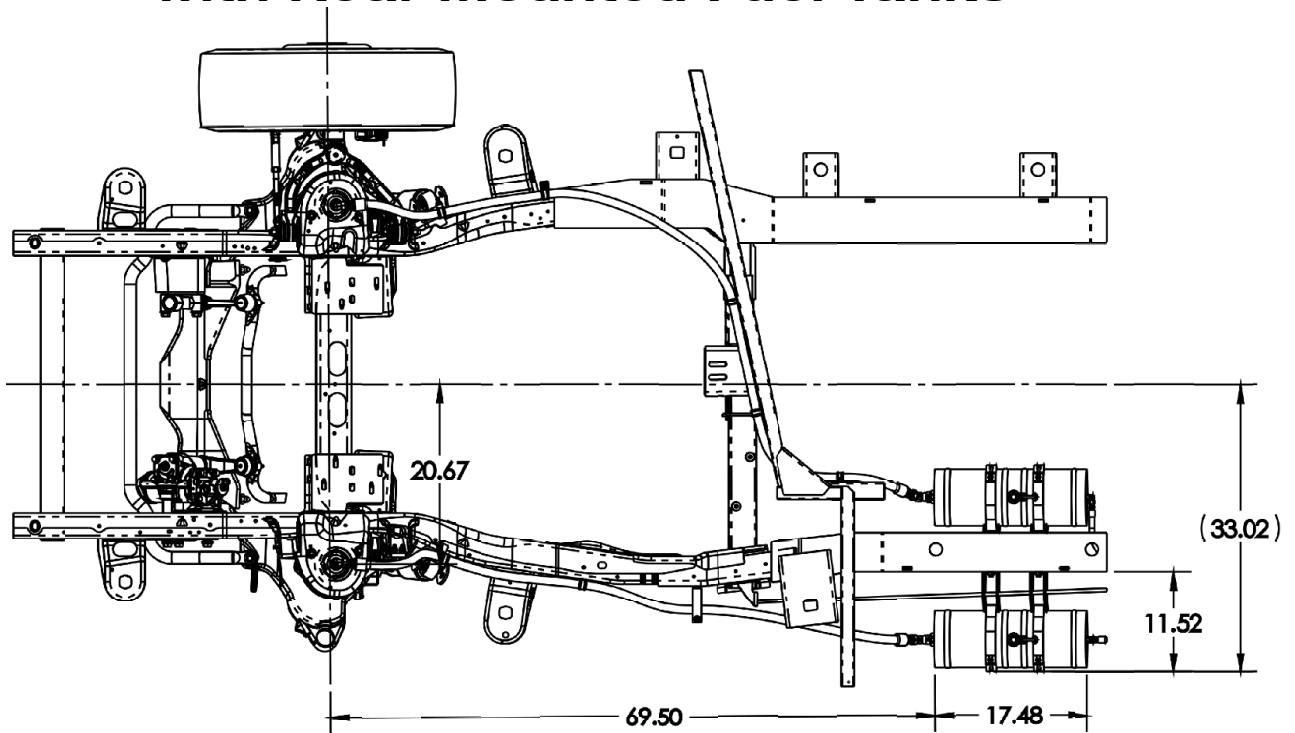

8.2' Design Ride Height
(Bottom of Crossmember to Ground)
4.08" Jounce Travel
3.79" Rebound Travel

Note:

- Vehicle Dimensions based on OEM Tires.
- Add or subtract SLR difference for different tires.



LiquidSpring™ LLC

4899 E 400 S
Lafayette, IN 47905

Phone: 765-474-7816

Fax: 765-474-7826

Web: www.liquidspring.com